

ELECTRICAL AND COMPUTER ENGINEERING DEPARTMENT

Electrical Engineering Major
(128 Semester Hours)

10/5/2009

REQUIRED COURSES WITHIN THE ENGINEERING COLLEGE

COURSE TITLE

NUMBER HRS. PREREQUISITES

Electrical Engineering Core Courses(43 hrs)

Orientation*a	ENGR 100	0	Admission to the College of Engineering
Introduction to Thermodynamics	CHE 201 or	3	MATH 181 and PHYS 141
Introduction to Thermodynamics	ME 205	3	PHYS 142
Introduction to Computing and Programming	CS 107	4	Credit or concurrent registration in MATH 180
Introduction to Electrical and Computer Eng.	ECE 115	4	Credit or concurrent registration in MATH 180
Circuit Analysis	ECE 225	4	MATH 220; & grade of C or bett. in PHYS 142 & grade of C or bett. in ECE 115
Introduction to Logic Design	ECE 265	4	MATH 180; and grade of C or better in ECE 115
Computer Organization I	ECE 267	3	CS 102 or CS 107 or CS 108
Discrete and Continuous Signals and Systems	ECE 310	3	MATH 220; & cr. or conc. reg. in ECE 225; or cr. or conc. reg. in ECE 210 for non-ECE students
Communication Electromagnetics	ECE 322	3	Grade of C or better in ECE 225
Electronics I	ECE 340	4	Grade of C or better in ECE 225
Probability and Random Processes for Engineers	ECE 341	3	ECE 310
Solid-State Device Theory	ECE 346	4	MATH 220, gr. of C or better in ECE 115, and a gr. of C or better in PHYS 142
Senior Design I	ECE 396	2	ENGL 161 and senior standing
Senior Design II	ECE 397	2	ECE 396
Professional Development Seminar	ECE 499	0	Open only to seniors; & approval of the dept. Must be taken in the student's last semester of study.

Electrical Engineering Advanced Core Courses(12 hrs)

(Students must complete at least three of the following courses.)

Communication Engineering	ECE 311	4	Grade of C or better in ECE 310
Digital Signal Processing I	ECE 317	4	Grade of C or better in ECE 310
Electronics II	ECE 342	4	ECE 340
Principles of Automatic Control	ECE 350	4	Grade of C or better in ECE 310
Microprocessor-Based Design	ECE 367	4	ECE 267; and gr. of C or bett. in ECE 265; or gr. of C or bett. in CS 366
RF and Microwave Guided Propagation	ECE 424	4	ECE 225 and ECE 322

Technical Electives(17 hrs)

(Those courses not used to meet the advanced EE core requirement can be used as technical electives. However, no more than a total of two courses below the 400 level can be used to meet the technical electives requirement. Also, no more than one course from outside the ECE Department can be used to meet the technical electives requirement.)

General PHYS III (Modern PHYS)	PHYS 244	3	Gr. of C or bett. in Phys 142, Phys 107/108 with an aver. gr. of B or bett. & cr. in MATH 181
Computer Communication Networks I	ECE 333	4	ECE 341 and CS 107
Integrated Circuit Engineering	ECE 347	3	CHEM 112 and grade of C or better in ECE 225
Computer Organization II	ECE 366	4	ECE 267; and grade of C or better in ECE 265
CAD-Based Digital Design	ECE 368	4	ECE 366
Operating Systems Concepts and Design*a	CS 385	4	CS 201, and CS 366 or ECE 267
Quasi-Static Electric and Magnetic Fields	ECE 401	3	ECE 322
Pattern Recognition I	ECE 407	3	MATH 220
Network Analysis	ECE 410	3	Grade of C or better in ECE 310
Introduction to Filter Synthesis	ECE 412	3	Grade of C or better in ECE 310
Image Analysis and Computer Vision I	ECE 415	3	MATH 310; or grade of C or better in ECE 310
Digital Signal Processing II	ECE 417	4	ECE 317
Statistical Digital Signal Processing	ECE 418	3	ECE 317 and 341
Introduction to Antennas and Wireless Propagation	ECE 421	3	ECE 225 and ECE 322
Electromagnetic Compatibility	ECE 423	3	ECE 322
Modern Linear Optics	ECE 427	3	ECE 310 and ECE 322
Analog Communication Circuits	ECE 431	4	ECE 311 and ECE 340
Digital Communications	ECE 432	3	ECE 311 and ECE 341

TECHNICAL ELECTIVES CONTINUED

TECHNICAL ELECTIVES CONTINUED

Multimedia Systems	ECE 434	3	ECE 317
Computer Communication Networks II	ECE 436	3	ECE 333
Wireless Communications	ECE 437	3	ECE 311 and ECE 341
Power Semiconductor Devices & Integ. Circuits	ECE 442	4	ECE 342 and ECE 346
Analysis & Design of Power Electronic Circuits	ECE 445	4	ECE 342; and grade of C or better in ECE 310
Transistors	ECE 448	3	ECE 346
Microdevices and Micromachining Technology	ECE 449	4	ECE 347; or consent of the instructor
Control Engineering	ECE 451	3	ECE 350
Robotics: Algorithms and Control	ECE 452	3	CS 201; & gr. of C or bett. in ECE 210 or gr. of C or bett. in ECE 225
Electromechanical Energy Conversion	ECE 458	3	Grade of C or better in ECE 225
Digital Systems Design	ECE 465	3	Gr. of C or better in PHYS 142; and Gr. of C or better in ECE 265 or Gr. of C or better in CS 366.
Advanced Computer Architecture	ECE 466	3	CS 366; or ECE 366
Introduction to VLSI Design	ECE 467	4	ECE 340
Analog and Mixed-Signal VLSI Design	ECE 468	4	ECE 467
Computer Systems Design	ECE 469	3	CS 366; or ECE 366 and ECE 368
Coding and Cryptography	MCS 425	3	Gr. of C or bett. in MCS 261 & CS 202 & MATH 310 or 320 or 330

Nonengineering and General Education Requirements(50 hrs)**COURSE TITLE****NUMBER HRS. PREREQUISITES**

General College Chemistry I*b	Chem 112	5	C or better in CHEM 101 or adequate performance on the UIC chemistry placement exam
Academic Writing I:WAPC	ENGL 160	3	Performance on Dept. Placement Test
Academic Writing II:WIR	ENGL 161	3	ENGL 160 or the equivalent
Exploring World Cultures course*a		3	
Understanding the Creative Arts course*a		3	
Understanding the Past course*a		3	
Understanding the Individual and Society course*a		3	
Understanding US Society course*a		3	
Calculus I*b	MATH 180	5	C or better in MATH 121 or app. perf. on the dept. pl. test
Calculus II*b	MATH 181	5	C or better in MATH 180
Calculus III*b	MATH 210	3	C or better in MATH 181
Introduction to Differential Equations I	MATH 220	3	C or better in MATH 210
General Physics I (Mechanics)*b	PHYS 141	4	Gr. of C. or better in MATH 180
General Physics II (Electricity & Magnetism)*b	PHYS 142	4	MATH 181; & Gr. of C or bett. in either in Phys 141 or both Phys 105/106

*a-Consult General Education section of the catalog for approved courses in this category;*b-Course approved for the Analyzing the Natural World General Education category

Additional Mathematics Requirement

(Students must complete at least one of the following courses.)

Applied Linear Algebra	MATH 310	3	"C" or better in MATH 210
Advanced Calculus I	MATH 410	3	"C" or better in MATH 210
Complex Analysis with Applications	MATH 417	3	"C" or better in MATH 210
Applied Partial Differential Equations	MATH 481	3	"C" or better in MATH 220
Numerical Analysis	MCS 471	3	"C" or better in MCS 275 or in CS 102 or 108 or cons. of inst.

FREE ELECTIVES(3 hrs)

Students must select* courses from outside the ECE Department.

(*Students preparing for the Fundamentals of Engineering Examination, which leads to becoming a Licensed Professional Engineer, are advised to use these hours to take the course CME 201, Statics; and one course from the following courses: CME 203, Strength of Materials; CME 260, Properties of Materials; ME 211, Fluid Mechanics I.)

UIC Electrical Engineering Curriculum - Suggested Schedule of Courses (3/1/07)

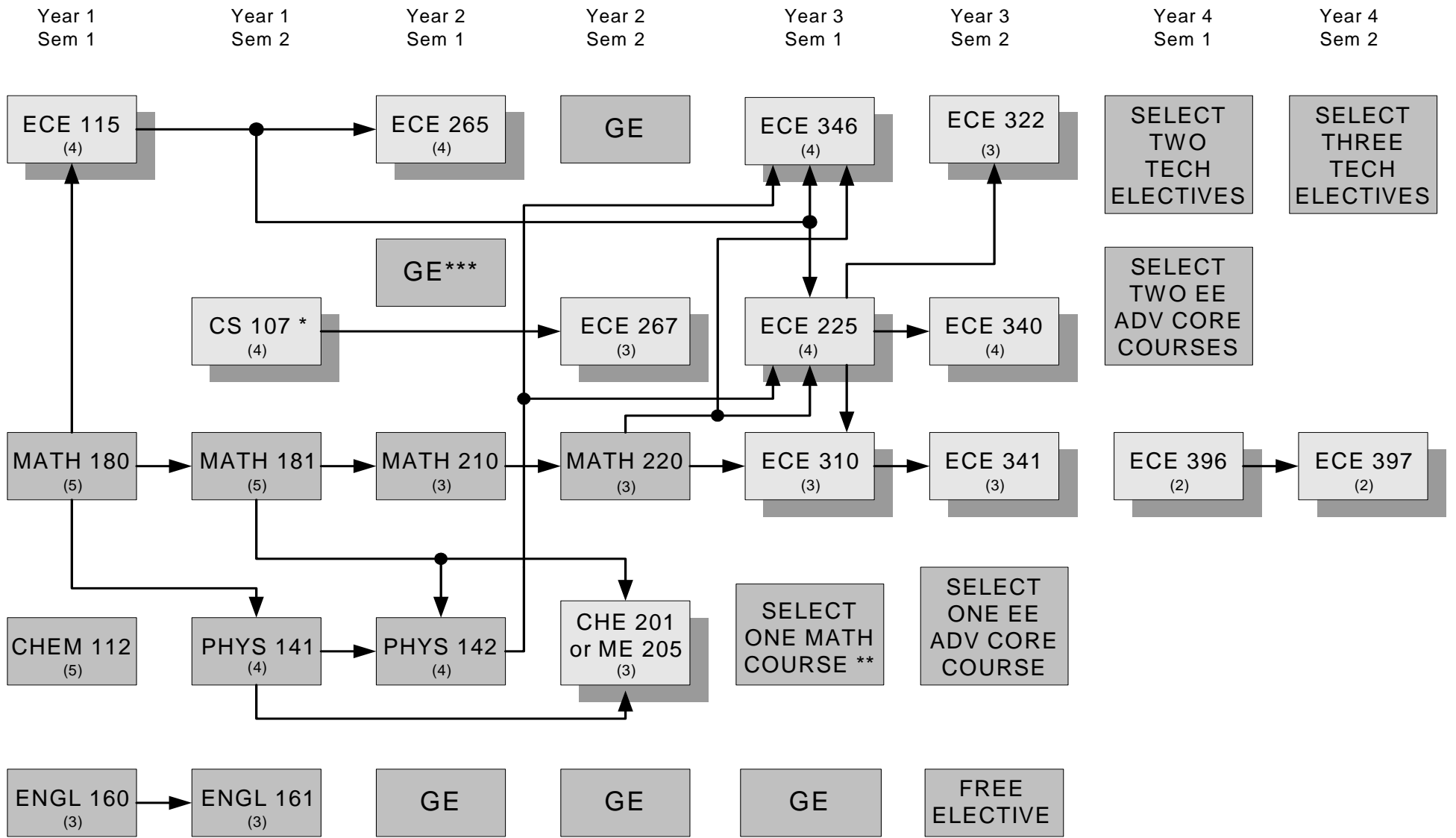

* CS 107 can be taken concurrently with MATH 180.
 ** Select one course from: MATH 310, 410, 417, 481 and MCS 471.
 *** General Education requirement

EE ADVANCED CORE COURSES
 ECE 311 (4), 317 (4), 342 (4), 350 (4), 367 (4) and 424 (4)
 (Must take at least three courses from this group.)